

## Model GSR-O ASH Control Description and Installation

### Product Description:

The Model GSR-O is an electronic energy-savings invention designed to smartly control the operation of glass door and frame heaters for walk-in coolers/freezers. The GSR-O efficiently runs the heater circuit enough to keep condensation from occurring on the door frame and glass without wasting additional energy. An optimized algorithm based on humidity of ambient air efficiently controls the door and frame heaters, only allowing run time when the air is humid enough to require heat. The Model GSR-O can pay for itself within months of installation based upon current costs for electricity. Its compact size and design for easy installation translates into minimum up-front costs and headaches.

### Installation:

1. Locate the unit on a flat surface inside the mullion or within a NEMA rated enclosure suitable for electrical applications. Drill two 7/64" diameter holes at the mounting-hole locations on both tabs of the unit. Mount the unit using two #6 sheet metal or self-tapping screws.
2. Disconnect the sensor cable from the main unit.
3. The position of the humidity sensor is critical to the unit's operation. If placed incorrectly it can lead to frosting, condensation on the glass or a loss of efficiency.

#### Dewpoint Sensor Mounting

There are two different mounting options – ledge mount or surface mount

##### A. Ledge Mount Instructions

If the installation is using a surface mount sensor with a ledge mount cover, break the mounting ear off the surface mount humidity sensor, then insert the humidity sensor all the way to the end of the ledge mount cover.

Locate an appropriate spot on the frame, so that the sensor is reading the temperature and humidity of the room, not the chilled space of the freezer or cooler. Drill a 1/4" diameter hole in the middle of the frame sill, so that the ledge mount cover will cover the hole and provide a wire path for the sensor connection.

Place the ledge mount enclosure over the hole so that it sets tightly against the frame sill, and place marks where the mounting ears are located. Drill two 7/64" diameter holes in the center of these marks, feed the Dew Point sensor cable through the 1/4" diameter hole, and secure the housing to the frame sill using the two black self-tapping screws.

Refer to the illustration below.

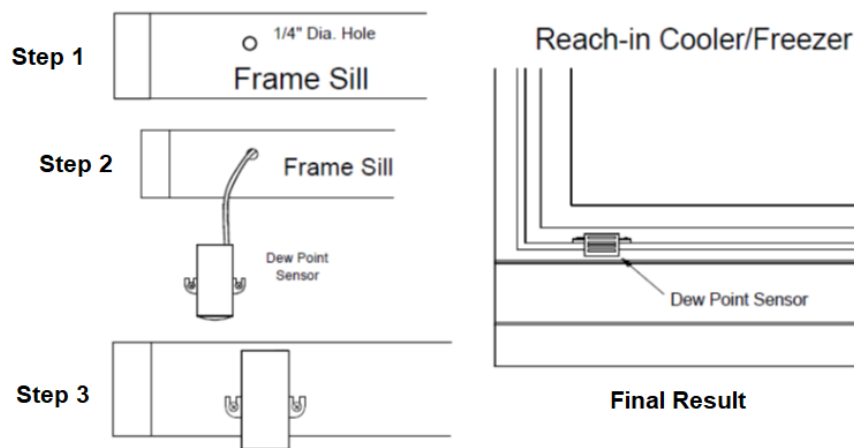

**B. Surface Mount Instructions**

Locate a spot above the center of the door frame, on the wall, to mount the dewpoint sensor.

Drill a 1/4" diameter hole through the wall, next to the mounting spot, above or below the cooler, depending upon where the main unit is mounted.

Run the loose end of the dewpoint sensor cable through the hole until the entire cable is on the other side of the wall. Clean the surface of the wall where the sensor is to be mounted and mount it to the wall using a #4 self-tapping screw.

Now place the surface mount cover over the dewpoint sensor and use the two black self-tapping screws supplied with the unit to mount on the wall. Refer to the illustration below.

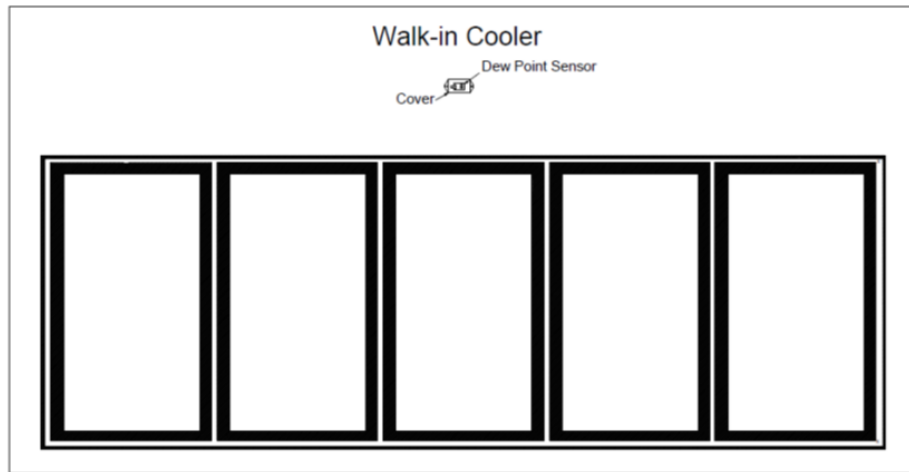

4. Re-connect the dewpoint sensor cable to the main unit.
5. Connect power and heater wires to the quick-connect terminals as follows:  
White- Connects to the shared neutral for the power and heater circuit (white wires).  
Black- Connects to the incoming line power (black wire).  
Red- Connects to the remaining heater wire (usually red).
6. Apply power to unit and make sure that the unit applies power to the heater circuit.

Troubleshooting		
Issue	Items to check	Resolution
Heater circuit does not energize	Check the voltage to ensure that it is between 95 to 128 VAC. If there is no AC voltage present, check the fuse or circuit breaker feeding the heater circuit. In the event that the fuse or breaker is blown, recheck your wiring and insure that the heater circuit does not exceed 10 amps.	Replace the Glass Sentry unit if no other issues are found.
Heater won't turn off	Make sure dewpoint sensor is connected and red LED on sensor is lit	Replace the Glass Sentry if no other issues are found
Condensation forming on glass	Check that dewpoint sensor is in proper location.	Rotate potentiometer adjustment in small increments until issue is resolved

**Technical Support**

For additional questions and support you may either direct your email to [sales@GlassSentry.com](mailto:sales@GlassSentry.com), or you may call (888) 780-4827.